



10.1" PCAP 10pt touch screen with Android and Power over Ethernet Technology

The ProLite TW1023ASC-B1P touch panel PC is a perfect choice for high-use environments such as retail, interactive POS, information desks or hospitality applications.

The Power over Ethernet technology (POE) allows to provide both data connection and power by a single cable, simplifying all installations. This monitor can operate in landscape, portrait or face-up orientation. Together with the built-in camera and speakers it offers limitless, interactive installation possibilities.



Connectivity

The RJ45 (LAN) connector supporting Power over Ethernet technology (POE) allows to provide both data connection and power by a single cable, which simplifies installation in areas where many cables would interfere with the environment.

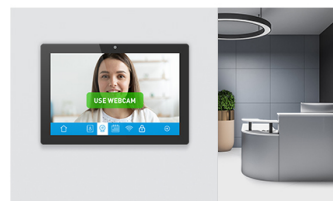

Built-in webcam & speakers

Making the screen a perfect solution for semi or fully automated reception solutions allowing businesses to track and manage visitor traffic at the front desk lobby without compromising on the safety and security of your staff, visitors and company assets.

01 DISPLAY CHARACTERISTICS

Design	Edge to edge glass
Diagonal	10.1", 25.5cm
Panel	IPS Panel Technology, LED
Native resolution	1280 x 800 (1 megapixel HD)
Aspect ratio	16:10
Panel brightness	450 cd/m ²
Brightness	385 cd/m ² with touch
Light transmittance	85%
Static contrast	1000:1 with touch
Response time (GTG)	25ms
Viewing zone	horizontal/vertical: 160°/160°, right/left: 80°/80°, up/down: 80°/80°
Colour support	16.7mIn 8bit
Viewable area W x H	216.6 x 135.4mm, 8.5 x 5.3"
Pixel pitch	0.1692mm
Bezel colour and finish	black, matte

02 TOUCH

Touch technology	projective capacitive
Touch points	10
Touch method	finger, glove (latex), capacitive stylus
Touch interface	USB

03 INTERFACES / CONNECTORS / CONTROLS

Digital signal output	HDMI x1 (mini HDMI, 1280x720 @60Hz)
Audio output	Speakers 2 x 1.5W
USB ports	x2 (2.0, 1 x MICRO with OTG)
RJ45 (LAN)	x1 (PoE)

04 FEATURES

Integrated software	Android 8.1 without GMS
CPU	Rockchip RK3288, quad-core Cortex-A17 up to 1.8GHz
GPU	Quad-core cortex A17
Storage	16GB eMMC
Memory	2GB DDR3
WiFi	IEEE802.11b/g/n
Bluetooth	4.0
Extra	auto-rotation, webcam (2 megapixel), microphone, SD card slot, anti-fingerprint coating
Max. non-stop operating time	24/7
Glass thickness	1.25mm
Glass hardness	7H

05 GENERAL

Applications

install new application / manage application, lock application, calculator, calendar, camera, chrome, alarm / clock / timer / stopwatch, email, manage files and folders, manage images / video / audio, organize albums, manage power on/off time, play audio files, search engine, system preferences, sound recorder, play video files

06 MECHANICAL

Orientation landscape, portrait, face-up

VESA mounting 75 x 75mm

07 ACCESSORIES INCLUDED

Guides quick start guide, safety guide

Other AC adapter

Cable cover yes

08 POWER MANAGEMENT

Power supply unit external

Power supply DC 12 V

Power usage 7W typical

09 SUSTAINABILITY

Regulations CE, RoHS support, ErP, WEEE, REACH

REACH SVHC above 0.1%: Lead

10 DIMENSIONS / WEIGHT

Product dimensions W x H x D 255 x 172 x 30.5mm

Box dimensions W x H x D 398 x 223 x 68mm

Weight (without box) 0.8kg

Weight (with box) 1.36kg

EAN code 4948570117116

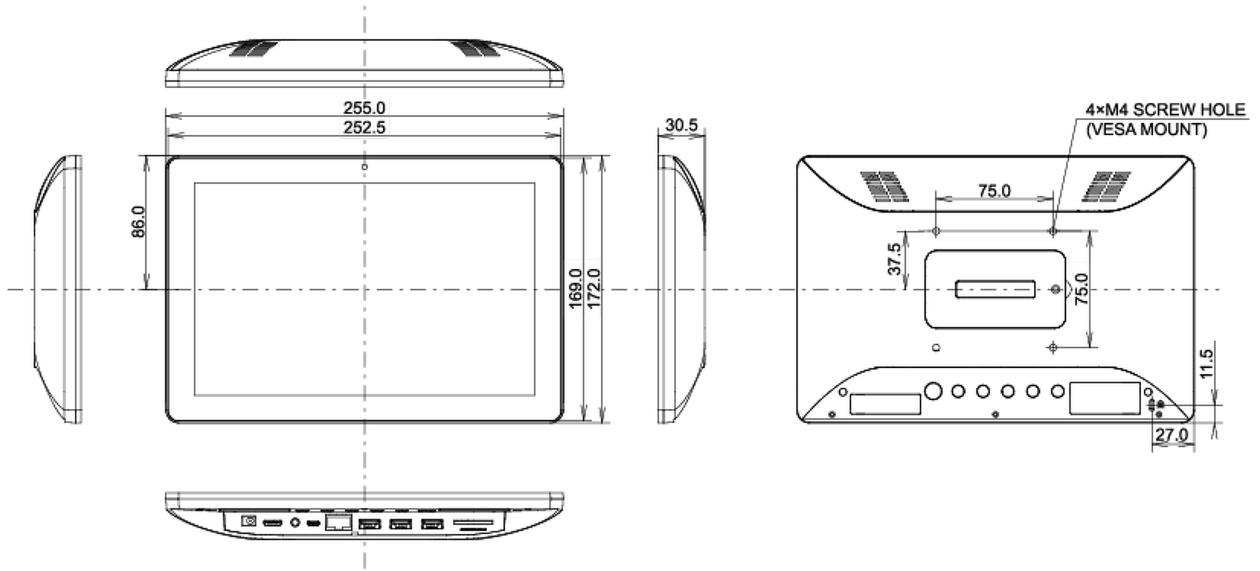

All trademarks and registered trademarks acknowledged. E & O E. Specification subject to change without notice. All LCD's comply with ISO-9241-307:2008 in connection with pixel defects.

© IIYAMA CORPORATION. ALL RIGHTS RESERVED