



### 15.6" Full HD PCAP 10pt touch screen with Android and POE Technology

The ProLite TW1523AS-B1P touch panel PC is a perfect choice for high-use environments such as retail, interactive POS, information desks or hospitality applications.

The Power over Ethernet technology (POE) allows to provide both data connection and power by a single cable, simplifying all installations. This monitor can operate in landscape, portrait and face-up orientation in 24/7 operating time. Together with the built-in microphone and speakers it offers interactive and almost limitless application possibilities.



#### Connectivity

The RJ45 (LAN) connector supporting Power over Ethernet technology (POE\*) allows to provide both data connection and power by a single cable, simplifying all installations. Together with the built-in microphone and speakers it offers interactive and almost limitless application possibilities. \*Requires 30W



#### Android OS

Thanks to Android OS, you can easily customize the display to your needs by installing applications directly to it.

## 01 DISPLAY CHARACTERISTICS

Design	Edge to edge glass
Diagonal	15.6", 39.5cm
Panel	IPS Panel Technology, LED
Native resolution	1920 x 1080 (2 megapixel HD)
Aspect ratio	16:9
Panel brightness	450 cd/m <sup>2</sup>
Brightness	385 cd/m <sup>2</sup> with touch
Light transmittance	85%
Static contrast	1000:1 with touch
Response time (GTG)	30ms
Viewing zone	horizontal/vertical: 170°/170°, right/left: 85°/85°, up/down: 85°/85°
Colour support	16.7mIn 8bit
Viewable area W x H	344.16 x 193.59mm, 13.5 x 7.6"
Pixel pitch	0.17925mm
Bezel colour and finish	black, matte

## 02 TOUCH

Touch technology	projective capacitive
Touch points	10
Touch method	finger, glove (latex), capacitive stylus
Touch interface	USB

## 03 INTERFACES / CONNECTORS / CONTROLS

Digital signal output	HDMI x1 (mini HDMI, 1920x1080 @60Hz)
Audio output	Speakers 2 x 2W
USB ports	x2 (2.0)
RJ45 (LAN)	x1 (PoE)

## 04 FEATURES

Integrated software	Android 8.1 without GMS
CPU	Rockchip RK3288, quad-core Cortex-A17 up to 1.8GHz
GPU	Quad-core cortex A17
Storage	16GB eMMC
Memory	2GB DDR3
WiFi	IEEE802.11b/g/n
Bluetooth	4.0
Extra	auto-rotation, microphone, SD card slot, anti-fingerprint coating
Max. non-stop operating time	24/7
Glass thickness	1.8mm
Glass hardness	6H

## 05 GENERAL

## Applications

install new application / manage application, lock application, calculator, calendar, chrome, alarm / clock / timer / stopwatch, email, manage files and folders, manage images / video / audio, organize albums, manage power on/off time, play audio files, search engine, system preferences, sound recorder, play video files

## 06 MECHANICAL

Orientation landscape, portrait, face-up

VESA mounting 100 x 100mm

## 07 ACCESSORIES INCLUDED

Guides quick start guide, safety guide

Other AC adapter

Cable cover yes

## 08 POWER MANAGEMENT

Power supply unit external

Power supply DC 12 V

Power usage 12W typical

## 09 SUSTAINABILITY

Regulations CE, RoHS support, ErP, WEEE, REACH

REACH SVHC above 0.1%: Lead

## 10 DIMENSIONS / WEIGHT

Product dimensions W x H x D 387 x 244 x 30.5mm

Box dimensions W x H x D 477 x 295 x 75mm

Weight (without box) 1.5kg

Weight (with box) 2.4kg

EAN code 4948570118014

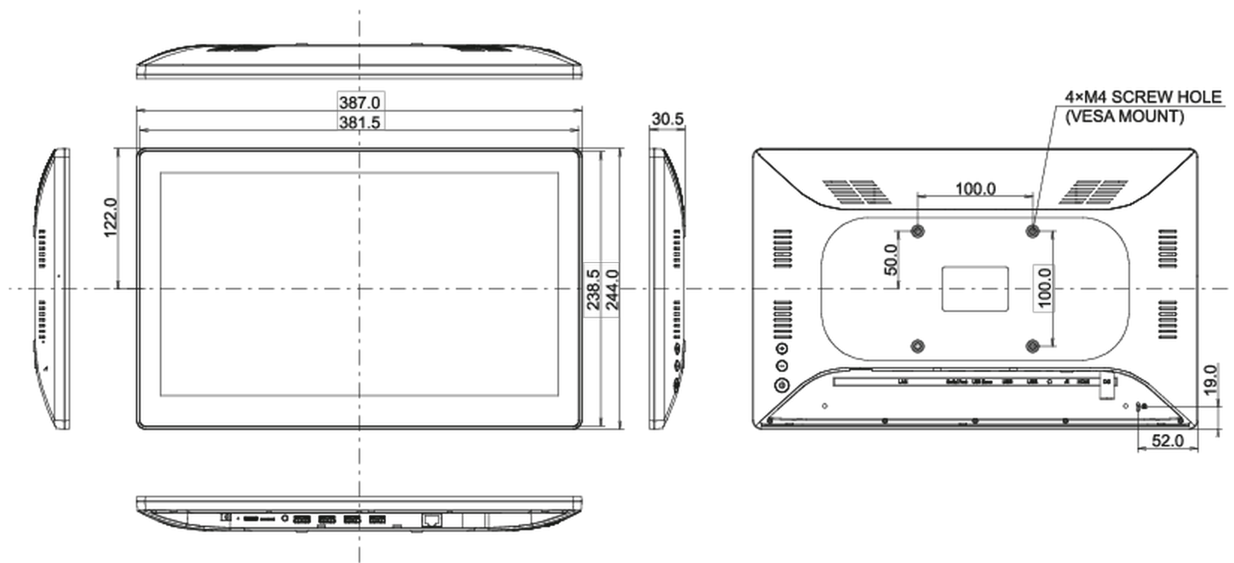

All trademarks and registered trademarks acknowledged. E & O E. Specification subject to change without notice. All LCD's comply with ISO-9241-307:2008 in connection with pixel defects.

© IIYAMA CORPORATION. ALL RIGHTS RESERVED